

M99 LMS Period II RESTAURANT COMPOSITE

D1811

Introduced 1932, last withdrawn 1962

68'

These etched sides can be built into a complete coach using products from our range as supplied in our full kits. Please refer to the panel opposite. Should you prefer they can also be used for scratchbuilding.

Restaurant composite coaches were used in the shorter expresses or through portions of longer formations where the limited number of meals required did not warrant the use of a full kitchen and open diners. The vehicles were 'neutral', with the class and seating being adjusted by staff to accommodate the demand.

Sample formations

Lancastrian 1934 BTK/TO/TO/CK/FO/CK/CK/BFK/RC/TO/TK/TK

Carlisle Perth 1938 BCK/RC/TO/BTK/BG/BG/POS

Glasgow Oban 1938 BCK/TK/BTK/TO/TO/RC/FO/BTK

Granite City 1949 TK/TK/BTK/TK/CK/CK/RC/TO/CK/BTK/BG

Running numbers

228-239 built 1932 Derby

Livery

The LMS coach body colour was maroon. Ends were also maroon with the detail picked out in black, but from the end of 1936 they were painted all over black. Fully panelled livery was applied with lining in black and gold leaf, later yellow. On flush sided coaches the lining was laid out as though the coach was panelled (so called 'psuedo-panelling') sometimes the verticals were at the edges of the window frames, otherwise they were on the centre of the panel between them. Simple lining was adopted at the beginning of 1934. In 1946 the yellow was replaced with a much lighter shade referred to as 'straw'. From 1949 coaches received BR crimson and cream. From 1956/7 BR maroon with simple lining was adopted.

Number and lettering styles, insignia and class designation placement did not always follow the changes of livery. For further information on a particular vehicle at a specific date please consult references and photographs.

Early coaches received lead grey roofs with black between the cantrail and rainstrip. All steel and later flush sided coaches had a metallic aluminium paint finish. However, in service the roof quickly took on an overall muddly grey colour.

Underframes and bogies were finished in black

Further information

LMS Coaches	Jenkinson & Essery	O.P.C.
Historic Carriage Drawings	Jenkinson & Campling	Ian Allan
Passenger Train Formations 1923-1983 LMS LM Region	Clive S Carter	Ian Allan

COMET MODELS coach components required to complete this coach are as follows

Underframe	UM1	Bogies	BM1
Underframe castings	UCM1	Roof castings	RC1/4
Ends	EM3	End castings	ECM3
Roof	C10	Interior	INT3
Gas cylinders	C18		

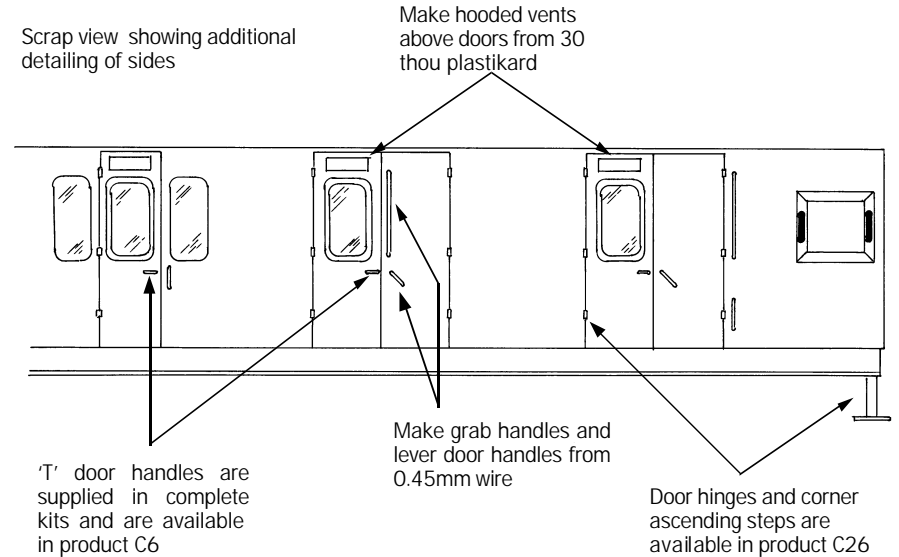

The ends are identical except that the train alarm gear is only fitted at the end shown on the roof plan overleaf

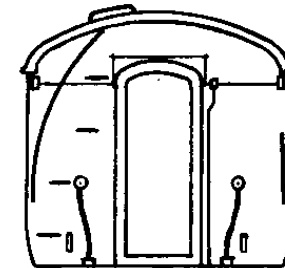

Train alarm gear this end

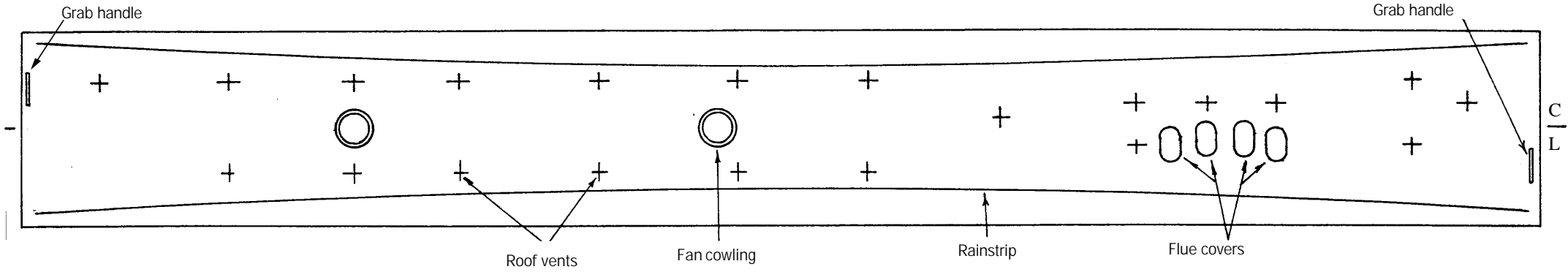

ROOF AND INTERIOR PLANS VIEWED FROM ABOVE

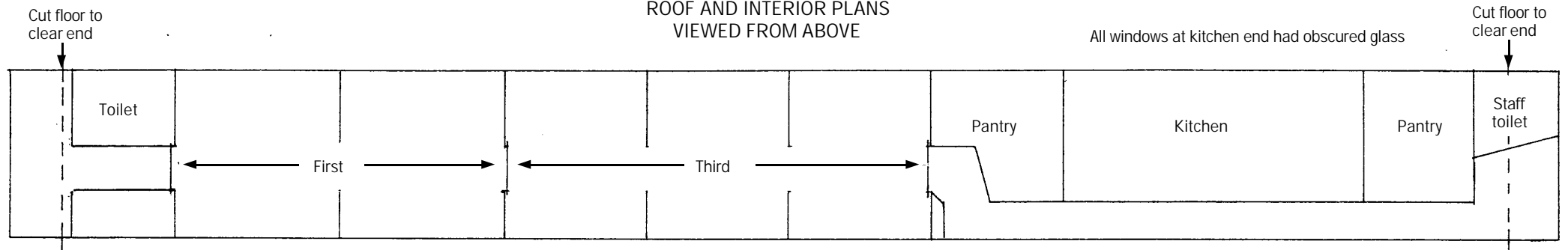

UNDERFRAME VIEWED FROM BELOW

