

M70 LMS Stanier DISTRICT INSPECTORS SALOON

D2046

Introduced 1940, withdrawn 1966 onwards (some extant 1977)

50'

These etched sides and ends can be built into a complete coach using products from our range as supplied in our full kits. Please refer to the panel opposite. Should you prefer they can also be used for scratchbuilding.

These 13 inspection saloons were built from 1940 to 1947 at Wolverton. They provided private, exclusive transport for the district inspectors and their senior staff, when visiting locations around the system, and to travel the lines. They were operated as a single vehicle, usually hauled by a small tender engine, an LMS 2P being typical. They were frequently propelled, thus allowing the staff more readily to observe the line from the leading saloon. Five of the coaches were built with inset door and grab handles, possibly for greater route availability, being slightly narrower.

Running numbers

45044/5	1940	45020/1/6*	1944
45046-8	1941	45035/6*	1947
45028-30	1942		*built with recessed door handles

Livery

The LMS coach body colour was maroon with black ends. Simple lining was adopted at the beginning of 1934. In 1946 the yellow was replaced with a much lighter shade referred to as 'straw'. From 1949 coaches received BR crimson and cream. From 1956/7 BR maroon with simple lining was adopted.

Number and lettering styles, insignia and class designation placement did not always follow the changes of livery. For further information on a particular vehicle at a specific date please consult references and photographs.

Although the 1940-42 builds probably received LMS simple lining, those built during and after the war (and from photographs 45026 certainly) were maroon but unlined.

Coaches left the works with the roof finished in a metallic aluminium paint. However, in service this quickly took on an overall muddy grey colour.

Underframes and bogies were finished in black

Modelling notes

For the recessed door handle versions carefully remove the areas within the half etched lines on the back of the sides behind the doors. Fit the blanking plates so that the half etched line on them is aligned with the door part line and the two dimples for the grab handle are both visible at the edge of the void. Drill out the holes for the door and grab handles. Note that the middle doors do not have grab handles as the steps are immediately below them.

Further information

LMS Coaches	Jenkinson & Essery	O.P.C.
Historic Carriage Drawings	Jenkinson & Campling	Ian Allan
Passenger Train Formations 1923-1983 LMS LM Region	Clive S Carter	Ian Allan

COMET MODELS coach components required to complete this coach are as follows

Underframe	UM3	Bogies	BM3
Underframe castings	Special	Roof fittings	Special
Ends	Included	End castings	ECM5
Roof	C10	Interior	Special

Scrap view showing additional detailing of sides

Make hooded vents above doors from 30 thou plastikard

Cross section showing shape and location of handrail for folding steps

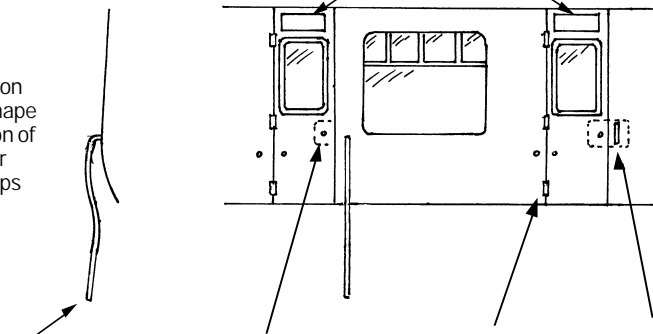

Make handle from 0.45mm wire

'T' door handles are supplied in complete kits and are available in product C6

Door hinges are available in product C26

Make grab handles from 0.45mm wire

The ends are identical

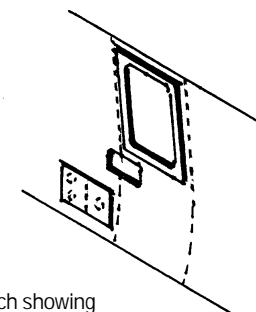

View inside coach showing fitting of blanking plates for recessed handle types

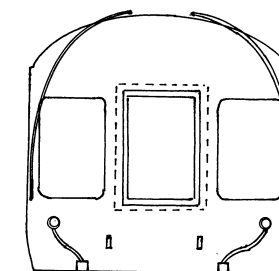

Fit large droplight behind centre window void

We would like to acknowledge the help of the Gloucester and Warwickshire Railway for their assistance in the research and preparation of this kit

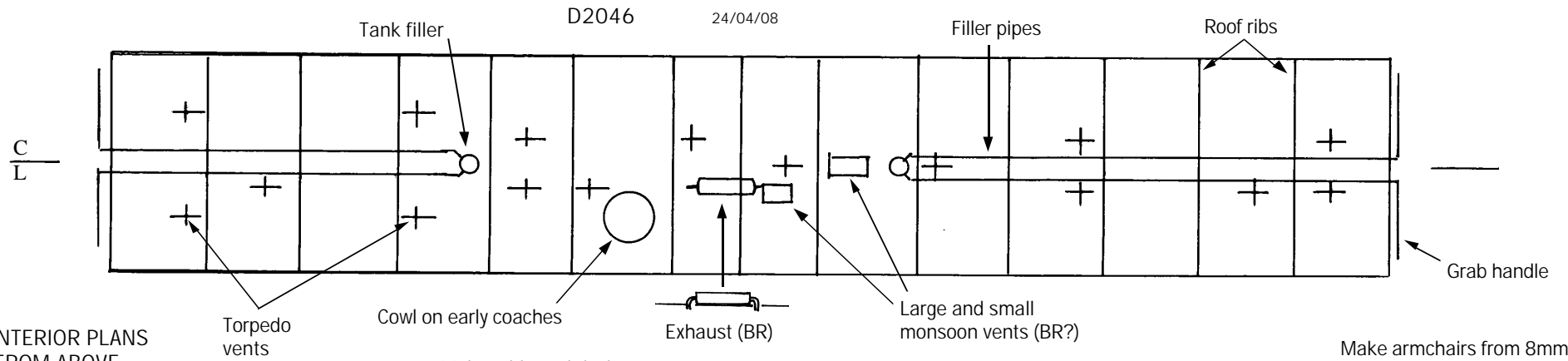

ROOF AND INTERIOR PLANS
VIEWED FROM ABOVE

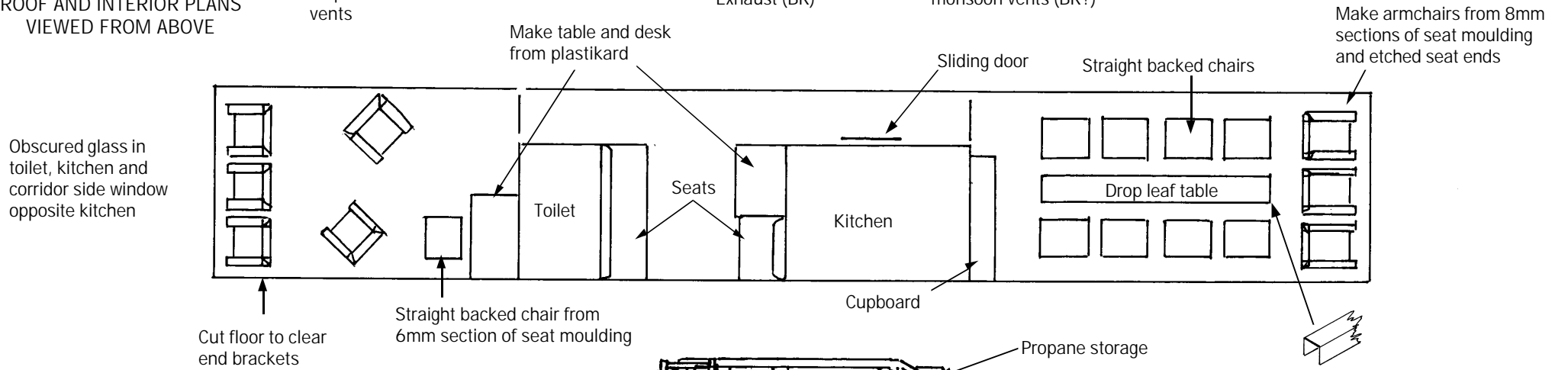

UNDERFRAME VIEWED
FROM BELOW

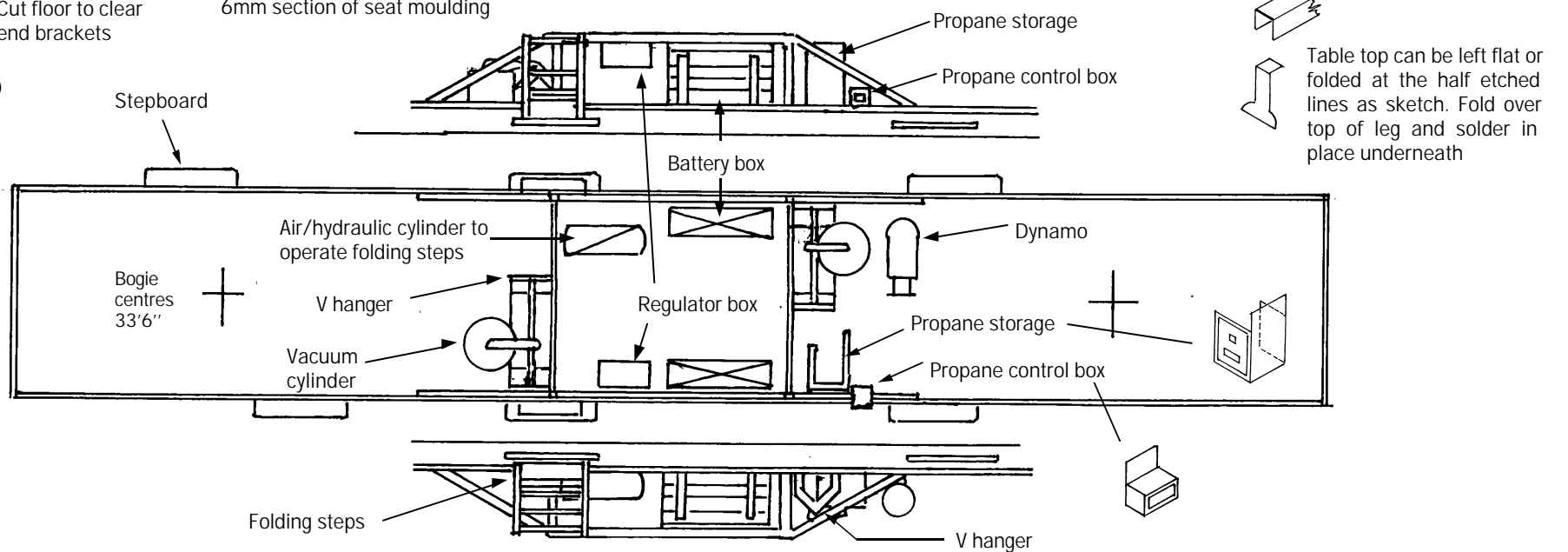

The steps are intended to give the appearance of being folded up in the running condition. With a little ingenuity they could be modelled in the down condition, but note that they would then project beyond the loading gauge. 4mm finescale modellers might wish to make them fully working, complete with figurine in bowler hat and all operated by DCC. Just joking.

- 1 Drill all dimples 0.5mm whilst items are still in the fret (14 holes per set of steps)
- 2 Fold top edge over 180° with half etch to the **outside** of the fold and solder down flat. Fold up the sides.
- 3 Thread 0.45mm wires A and B through the top and middle holes in the frame and operating arms. With the arms tight against the inside of the frame solder only the top wire A in place. Trim off inside and outside then withdraw wire B..
- 4 Fold up the sides and solder in the step brace (as seen in 5). Fit to the frame by replacing wire B with the top of the step against the frame (see side view). Solder the wire in place and trim off on the outside. With the tip of a knife break off the cross brace at X.
- 5 Proceed as described above for the bottom step, this time using wire C. Centre the step in the frame and solder the wire in place on the outside. Break off the cross braces in the step and the frame at points Y and Z. Repeat from 1 for the second set of steps.
- 6 Fit the step assembly by locating the fold over section onto the projecting lip of the solebar then angle inwards at the bottom until it is against the truss and solder in place. Check that the steps will clear your platforms and other lineside features.

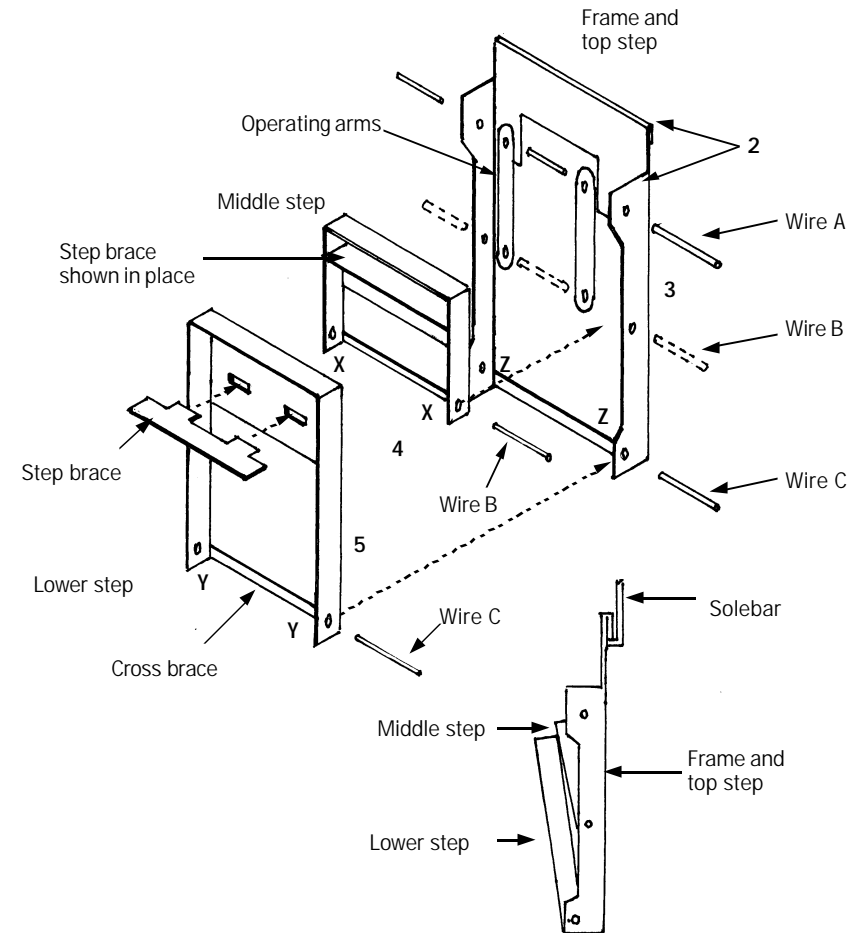

Assembly of the ends, sides and roof

- 1 Solder the large droplight in place behind the centre window.
- 2 Bend up the reinforcement piece to 90° and solder a nut over the hole. Space up the reinforcement piece by the thickness of the floor (18 thou). Tack solder to the inner face of the end ensuring that it is both central and vertical, using the half etched mark as a guide. When satisfied, complete the joint.
- 3 Tack the sides to the ends, ensuring that the bottom of the side is exactly level with the bottom of the end. **NB** the sides fit **outside** the ends.
- 4 Cut the roof to length, remove a small section of the rebate at all four corners to achieve a close fit over the ends.

