

M21 LMS Period II OPEN THIRD

D1807

Introduced 1931, last withdrawn 1966

57'

These etched sides can be built into a complete coach using products from our range as supplied in our full kits. Please refer to the panel opposite. Should you prefer they can also be used for scratchbuilding.

This open third was the most numerous Period II design, 299 being built in 1931/2. The etch represents the 1931 build, but if you wish to model the 1932 version then the etch should be modified to show hooded vents over all the windows except the second and fifth where Stones vents should be fitted.

Sample formations

Inverness-Kyle 1938

CK/CK/RU/TO/TO/BG

Western Division extras/excursions

BCK/TO/TO/TO/TO/BTO

BCK/TO/TO/TO/TO/TO/TO/TO/BTO

Running numbers

8581-8720 built 1931 at Derby

8781-8879

built 1932 at Derby

8721-8780 built 1931 at Wolverton

1931 builds had panel lining between windows. 1932 builds had suspended gangways.

1951 Push-pull conversions 8723/48/8865 became 3484/5/6

Livery

The LMS coach body colour was maroon. Ends were also maroon with the detail picked out in black, but from the end of 1936 they were painted all over black. Fully panelled livery was applied with lining in black and gold leaf, later yellow. On flush sided coaches the lining was laid out as though the coach was panelled (so called 'psuedo-panelling') sometimes the verticals were at the edges of the window frames, otherwise they were on the centre of the panel between them. Simple lining was adopted at the beginning of 1934. In 1946 the yellow was replaced with a much lighter shade referred to as 'straw'. From 1949 coaches received BR crimson and cream. From 1956/7 BR maroon with simple lining was adopted.

Number and lettering styles, insignia and class designation placement did not always follow the changes of livery. For further information on a particular vehicle at a specific date please consult references and photographs.

Early coaches received lead grey roofs with black between the cantrail and rainstrip. All steel and later flush sided coaches had a metallic aluminium paint finish. However, in service the roof quickly took on an overall muddy grey colour.

Underframes and bogies were finished in black

Further information

LMS Coaches

Jenkinson & Essery

O.P.C.

Historic Carriage Drawings

Jenkinson & Campling

Ian Allan

Passenger Train Formations

1923-1983 LMS LM Region

Clive S Carter

Ian Allan

COMET MODELS coach components required to complete this coach are as follows

| | | | |
|---------------------|------|---------------|------|
| Underframe | UM2 | Bogies | BM2 |
| Underframe castings | UCM1 | Roof castings | RC1 |
| Ends | EM3 | End castings | ECM1 |
| Roof | C10 | Interior | INT4 |

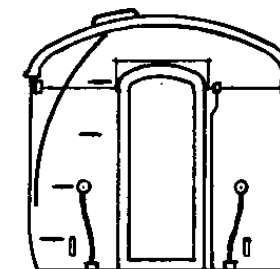
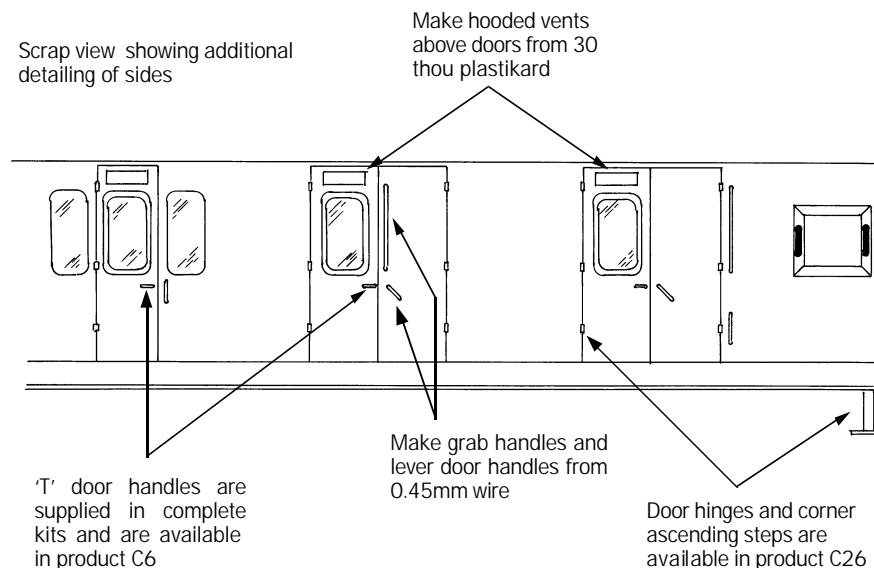

The ends are identical except that the train alarm gear is only fitted at the end shown on the roof plan overleaf

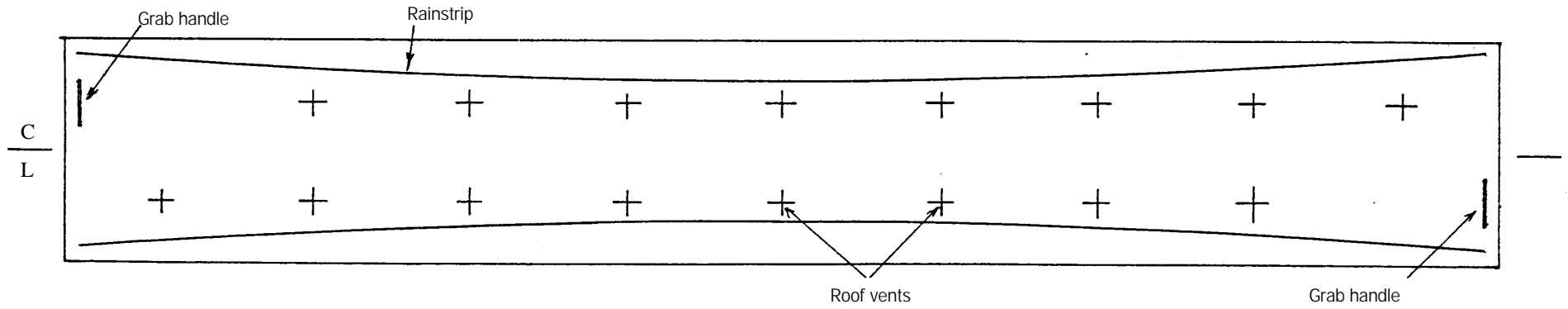

ROOF AND INTERIOR PLANS VIEWED FROM ABOVE

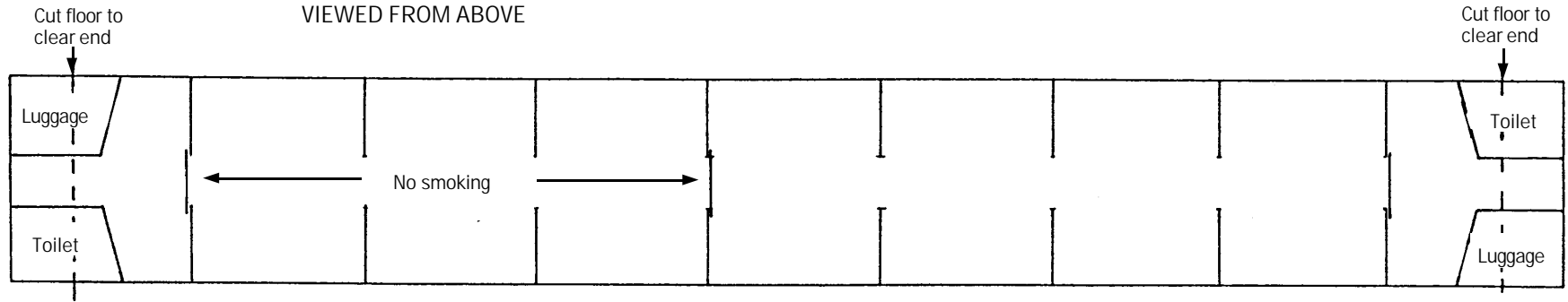

UNDERFRAME VIEWED FROM BELOW

